

REAL ESTATE CONTRACT

SELLER: LAKE COUNTY TRUST NO.1720
ADDRESS: 8400 OAKWOOD, MUNSTER, IN 46321
BUYER: THE LAMAR COMPANIES OR ITS NOMINEE
ADDRESS: 1770 W. 41ST AVENUE, GARY, IN 46408

Buyer hereby agrees to purchase and Seller agrees to sell the following described real estate, on the terms and conditions herein set forth.

DESCRIPTION OF PROPERTY: One of Three (3) Parcels owned by Seller and being purchased by Buyer, which parcel is legally described as follows:

LEGAL DESCRIPTION (Permission to attach hereto at any time hereafter)

STREET ADDRESS VACANT LAND ALONG 80/94, LAKE STATION, INDIANA ("the Property")
(SEE ATTACHED SURVEY)

LOT SIZE: APPROXIMATELY X feet.

Seller represents and warrants to Buyer that access for ingress and egress as Buyer requires to install, construct, maintain or relocate Buyer's outdoor advertising structures and the utilities servicing same at each of the Parcels is currently available to Buyer without any further grant of easement. In the event such access is not available, Seller agrees that the Property to be conveyed shall include a grant of easement for access, ingress and egress.

PRICE AND TERMS:

PURCHASE PRICE: TWO HUNDRED, SIXTY SIX THOUSAND, SIX HUNDRED AND SIXTY SIX AND 67/100 DOLLARS: (\$266,666.67) payable as follows:

- A. Upon receipt by Buyer of all permits which Buyer deems necessary or desirable for Buyer's intended use of the Property for illuminated outdoor advertising structure(s), Buyer shall deposit with Seller the sum of ONE HUNDRED TWENTY FOUR THOUSAND, FOUR HUNDRED FORTY FOUR AND 39/100 DOLLARS (\$124,444.39) as an Earnest Money Deposit, to be applied against the Purchaser Price at Closing;
B. Balance of the Purchase Price ONE HUNDRED FORTY TWO THOUSAND, TWO HUNDRED TWENTY TWO AND 28/100 DOLLARS (\$142,222.28) plus or minus prorations, if any, shall be paid at Closing by cash, cashier's check, certified funds or wire transfer.

CLOSING:

The Closing shall be on OCTOBER 1, 2008 at the office of Chicago Title Insurance Company, 2200 N. Main Street, Crown Point, Indiana 46307

INTENDED USE: Seller and Buyer acknowledge and agree that Buyer is acquiring the Property as one of the three parcels owned by Seller and being purchased by Seller. Buyer intends to improve each parcel with an illuminated outdoor advertising structure which may include electrified advertising face(s), telecommunication devices or other activities necessary or useful in Buyer's use of the structure to be situated on the Property. Upon execution of this Real Estate Contract, Buyer shall apply to all applicable governmental authorities (local, state, and/or federal) for all permits necessary or desirable for construction and operation of the structure(s) required in connection with Buyer's intended use of the Property. In the event Buyer cannot procure all permits which Buyer, in its sole discretion, deems necessary or desirable to enable Buyer to use the Property as intended, within one hundred eighty (180) days from the date of this Real Estate Contract, then this agreement shall be cancelled and of no further force and effect.

POSSESSION:

Seller shall deliver possession of the Property to the Buyer upon receipt of the Earnest Money Deposit. Upon Seller's delivery of possession of the Property to Buyer, Buyer shall be entitled to construct, repair, relocate such outdoor advertising structure(s), including necessary structures, advertising devices, power poles, communication devices and connections, with the right of access to and egress from structure(s) by Buyer's employees contractors, agents, and vehicles and the right to survey, maintain advertising, maintain telecommunication devices or other activities necessary or useful in Buyer's use of the structure(s) to be situated on the Property. Seller acknowledges and agrees that Buyer shall be entitled to retain all income associated with the use of the structure(s) or the Property during the period commencing with Seller's delivery of possession of the Property to Buyer and terminating with the Closing. Recognizing that Buyer, may, after taking possession of the Property in accordance with this Agreement, install valuable improvements to the Property, the parties agree that in the event the Closing does not take place, due to no fault of the Buyer, in addition to and not in replacement of all other remedies available to Buyer at law or in equity for Seller's default, Buyer shall be entitled to retain possession of the Property for a period of fifteen (15) years, commencing on the day possession was delivered by Buyer, and terminating fifteen (15) years thereafter, pursuant to the terms of the Lease Agreement attached hereto and incorporated herein by reference. The Lease Agreement shall be executed by the parties, contemporaneously with this Real Estate Contract, and held in escrow by Buyer's attorney, to be delivered to Buyer on the earlier of (a) the Closing or (b) Seller's default under this Real Estate Contract for Seller's use to convey the Property to Buyer in exchange for payment of the Purchase Price.

2007 098118

STATE OF INDIANA
LAKE COUNTY
FILED FOR RECORD
MICHAEL A. BROWN
RECORDS CLERK
NOV 4 2007

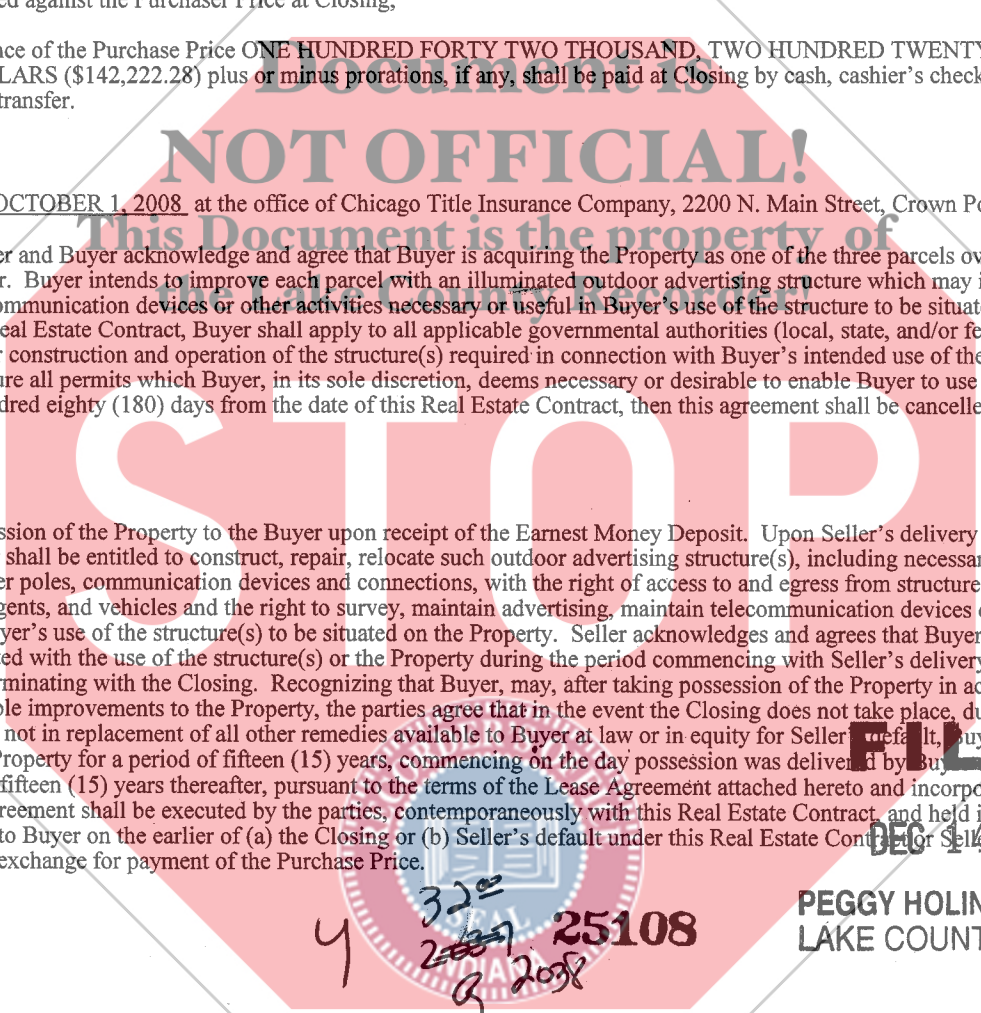

PEGGY HOLINGA KATONA
LAKE COUNTY AUDITOR

TITLE EVIDENCE:

Seller, at his expense, shall furnish not less than five days prior to the closing date, a title commitment for an owner's title insurance policy issued by Chicago Title Insurance Company, in the amount of the Purchase Price covering the date hereof subject only to (a) the general exceptions contained in the title policy; (b) the title exceptions set forth below as "permitted exceptions"; and (c) title exceptions pertaining to liens or encumbrances of an ascertainable amount which the Seller agrees to remove at closing from the proceeds hereunder. Any delay in delivery of the title commitment which is caused by the Buyer shall extend the time for delivery thereof by the Seller by such period of delay. If the title commitment discloses exceptions not provided for herein, the Seller shall have until Closing to remove said exceptions or to acquire title insurance covering said unpermitted exceptions. If Seller fails to remove said exceptions or obtain additional insurance within the time stated herein, Buyer may elect to terminate this Contract and in such event the Lease Agreement attached hereto shall be delivered to Buyer and Buyer shall retain the right to pursue any and all remedies available to Buyer at law or in equity for Seller's default in performance.

DEED (CONVEYANCE, LIENS, ENCUMBRANCES):

Seller shall convey title to the Property to Buyer or Buyer's nominee by a recordable trustee's deed, subject only to the following permitted exceptions, provided none of which shall materially restrict the Buyer's intended use of the Property: (a) general real estate taxes not due and payable at the time of closing; (b) building lines and building laws and ordinances, use or occupancy restrictions, conditions and covenants of record; (c) zoning laws and ordinances which conform to the present usage of the Property; (d) public and utility easements which serve the Property; and (e) public roads and highways, if any.

TRANSFER TAX STAMPS:

Seller shall pay for the State of Indiana and county real estate transfer tax stamps. Any municipal transfer tax shall be paid by the party designated in the ordinance of the municipality imposing the tax. If the local ordinance is silent, Buyer shall pay the costs of the stamps.

PRORATIONS:

The Property is part of a larger tract of real estate, currently identified by the one key number by the Lake County Assessor and Treasurer. Seller will be responsible for and pay the real estate taxes assessed against the real property of which the Property is a part until the Property is identified by separate key number(s) and will provide Buyer with proof of payment within thirty (30) days after written request from Buyer. Buyer agrees to prepare and complete, at Buyer's expense, the documentation required by the Lake County Assessor's Office in order to complete the tax division required to procure separate key number(s) for the Property. Seller agrees to execute all documentation required to be executed in connection with the tax division process.

DAMAGE BY CASUALTY BEFORE CLOSING:

If the improvements on the property shall be destroyed or materially damaged by fire or other casualty prior to closing, the provisions of the Uniform Vendor and Purchaser Risk Act of Indiana shall apply.

SURVEY:

In the event Buyer or Buyer's lender shall request any survey work, said survey work shall be a responsibility of Buyer and provided at Buyer's expense. In the event said survey discloses encroachments, these encroachments shall be insured by the title company for Buyer and Buyer's lender at Seller's expense.

LAND TRUST BENEFICIARY:

Seller under this Real Estate Contract is an Indiana land trust. If this Real Estate Contract is executed by individuals rather than the Trustee of said trust, the individuals represent and warrant that they are all the beneficiaries of said trust; that they have signed their names to this Contract to indicate they are the beneficiaries of said trust; that by their signature they can bind the Trust and therefore guarantee their performance of this Contract; and that they hold the sole power of direction with regard to said trust.

COMMISSION: No real estate broker was used in this transaction.

PERFORMANCE/DEFAULT:

The Earnest Money shall be paid to Seller, for the benefit of the parties hereto, and applied to the Purchase Price at Closing. The Lease Agreement attached hereto as Exhibit A shall be executed by the parties, and held in escrow by Buyer's attorney, to be delivered to Buyer on the earlier of (a) the Closing or (b) Seller's default under this Real Estate Contract or Seller's refusal to convey the Property to Buyer in exchange for payment of the Purchase Price.

If Buyer defaults, all earnest money shall be forfeited to Seller, provided, however, that such forfeiture shall not be the exclusive remedy of Seller, and Seller shall retain said forfeited earnest money without prejudice to any other remedy Seller has at law or in equity. Upon entry of a court order finding Buyer in default or if Buyer acknowledges Buyer's default, the Lease Agreement attached hereto as Exhibit A, shall be terminated and thereafter Seller shall not be bound to the terms of the lease. If Seller defaults, the earnest money, at the option of the Buyer, shall be refunded to Buyer, but such refund shall not release Seller from his obligations under this Contract or the Lease Agreement or in any way limit or restrict the right of Buyer to pursue other legal or equitable remedies. In the event of any default or nonperformance by either of the parties where the parties cannot agree as to the disposition of the earnest money, Escrowee may give written notice to all parties of Escrowee's intention to file, thirty (30) days thereafter, an action with the appropriate Circuit Court in the nature of an interpleader for the purpose of depositing the earnest money with the Clerk of the Circuit Court. The Escrowee shall be reimbursed from the earnest money for all court costs related to the filing of the interpleader action.

SELLER'S REPRESENTATIONS. Seller represents and warrants to Purchaser as follows (which representations are to Seller's

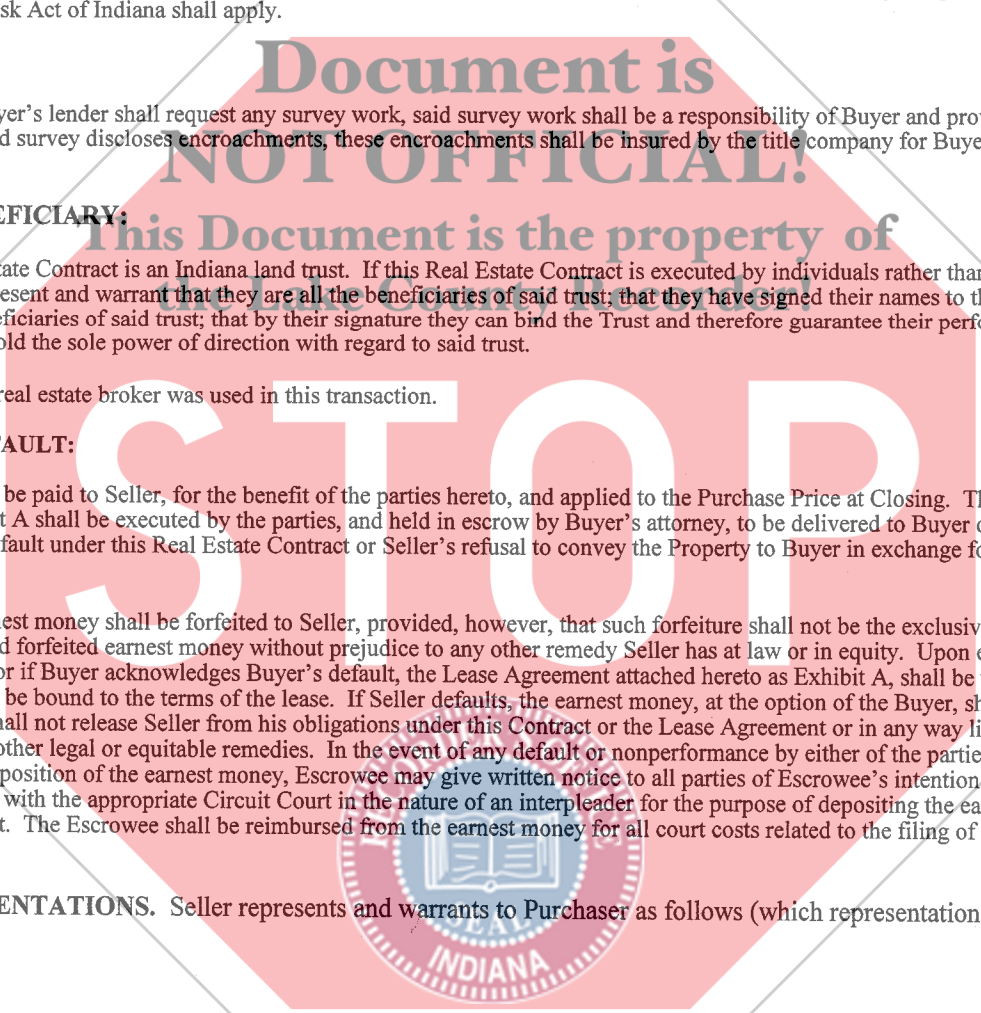

actual knowledge):

A. Seller has the requisite power and authority to enter into and perform the terms of this Agreement. This Agreement has been duly executed and delivered by Seller and, assuming execution and delivery of this Agreement by Purchaser, is a legal, valid and binding obligation of Seller enforceable against it in accordance with its terms.

B. There will not be as of the Closing, any leases, tenancies, licenses, concessions, franchises, options or rights of occupancy with respect to the Property, other than those, if any, previously disclosed to Purchaser ("Existing Tenancies").

C. Seller represents and warrants that he has not received any notice from any governmental body of any ordinance, zoning or building code violation, condemnation proceeding, pending rezoning or special assessment proceedings affecting the Property.

D. Seller represents and warrants that no Hazardous Materials have been located on the Property or have been released into the environment, or discharged, placed or disposed of at, on or under the Property; (ii) no underground storage tanks have been located on the Property; (iii) the Property has never been used as a dump for waste material; and (iv) the Property complies with any applicable governmental law, regulation or requirement relating to environmental and occupational health and safety matters and Hazardous Materials. The term "Hazardous Materials" shall mean any substance, material, waste, gas or particulate matter which is regulated by any local governmental authority, the State of Illinois, or the United States Government, including, but not limited to, any material or substance which is (i) defined as a "hazardous waste", "hazardous material", "hazardous substance", "extremely hazardous waste", or "restricted hazardous waste" under any provision of Indiana law, (ii) petroleum, (iii) asbestos, (iv) polychlorinated biphenyl, (v) radioactive material, (vi) designated as a "hazardous substance" pursuant to Section 311 of the Clean Water Act, 33 U.S.C. §1251 *et seq.* (33 U.S.C. §317), (vii) defined as a "hazardous waste" pursuant to Section 1004 of the Resource Conservation and Recovery Act, 42 U.S.C. §6901 *et seq.* (42 U.S.C. §6903), or (viii) defined as a "hazardous substance" pursuant to Section 101 of the Comprehensive Environmental Response, Compensation, and Liability Act, 42 U.S.C. §9601 *et seq.* (42 U.S.C. §9601). The term "Environmental Laws" shall mean all statutes specifically described in the foregoing sentence and all federal, state and local environmental health and safety statutes, ordinances, codes, rules, regulations, orders and decrees regulating, relating to or imposing liability or standards concerning or in connection with Hazardous Materials.

E. Seller agrees not to erect or allow any other off-premises advertising structures on property owned or controlled by Seller within five hundred (500) feet of Purchaser's advertising structure(s) on the Property or to erect or allow any other obstruction of highway view or any vegetation that may obstruct the highway view of its advertising structure(s). Seller agrees to include this restriction in any and all contracts for sale of any of Seller's property within five hundred (500) feet of the Property. This representation, warranty and obligation shall survive the Closing, and in the event Seller should breach any of the obligations contained herein, Purchaser shall be entitled to all remedies at law and in equity, and may further remove any other such advertising structure, obstruction or vegetation at Purchaser's expense and Seller specifically authorizes such entry upon Seller's property.

F. Seller is not a "foreign person" as defined in the Federal Foreign Investment in Real Property Tax Act of 1980 and the 1984 Tax Reform Act, as amended.

PURCHASER'S REPRESENTATIONS. Purchaser represents to Seller as follows (which representations are to Purchaser's actual knowledge):

A. Purchaser has the requisite power and authority to enter into and perform the terms of this Agreement. The execution and delivery of this Agreement and the consummation of the transaction contemplated hereby, by Purchaser, have been duly authorized by all necessary parties and no other proceedings on the part of Purchaser are necessary in order to permit it to consummate the transaction contemplated hereby. This Agreement has been duly executed and delivered by Purchaser and, assuming execution and delivery of this Agreement by Seller, is a legal, valid and binding obligation of Purchaser enforceable against it in accordance with its terms.

Should any representation or warranty of Purchaser made pursuant to this Agreement not be true and correct as of the date upon which Closing is to occur in all material respects then Purchaser shall be deemed to be in default under this Agreement.

GENERAL CONDITIONS AND STIPULATIONS:

- (a) Both Seller and Buyer agree to execute all documents and provide all information necessary to enable any lender to issue a commitment for mortgage or trust deed and to close this sale.
- (b) All notices herein required shall be in writing and served upon the parties at the addresses shown on this Contract or upon the attorney for such party. In the event the name and address of the Seller or the attorney for the Seller or the attorney for the Seller is unknown, written notice may be served upon the listing broker as agent for such Seller. Facsimile transmission of any offer, acceptance, notice or rider herein provided to the parties, their broker or attorney, shall constitute sufficient notice or acceptance. Original documents shall be forwarded in all instances within three (3) business days of such notice. Notice to any one party of a multiple person party shall be sufficient service to all.
- (c) This Contract and any Exhibits attached hereto shall constitute the entire agreement and understanding between the Seller and Buyer, and there are no other agreements, representations or understandings, oral or written, between the parties with respect to the subject matter of this Contract. No alteration, modification, or amendment to this Contract shall be valid unless in writing and signed by all parties.

- (d) This Contract shall be binding upon and inure to the benefit of the parties and their respective heirs, successors, legal representatives and permitted assigns. The parties agree to execute and record a Memorandum of Contract.
- (e) Where in this Contract masculine pronouns are used or words indicating the singular number appear, such words shall be considered as if feminine or neuter pronouns or words indicating the plural number were used where the context indicates the propriety of such use.
- (f) The invalidity of any paragraph or subparagraph of this Contract shall not impair the validity of any other paragraph or subparagraph. If any provision of this Contract is determined to be unenforceable by a court, such provision shall be deemed severable and this Contract may be enforced with such provision severed or as modified by such court.
- (g) Buyer shall apply for any and all necessary zoning changes.
- (h) Buyer's obligations hereunder are contingent upon Buyer obtaining all zoning and permits necessary to allow an advertising billboard structure to be erected on the Property. In the event that Buyer cannot not obtain the zoning and/or permits necessary to allow Buyer to construct and operate three advertising billboard structures on the Property, Buyer shall have the right to declare this Agreement terminated. Thereafter, neither party shall have any further obligation to the other. The tender of the Earnest Money from Buyer to Seller shall constitute a waiver of the zoning and permit contingencies.

THIS IS A LEGALLY BINDING CONTRACT WHEN SIGNED. IF NOT UNDERSTOOD, SEEK LEGAL ADVICE BEFORE SIGNING.

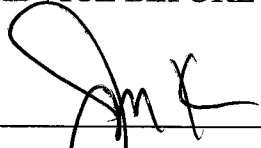
BUYER(S):  SELLER(S): SEE SIGNATURE PAGE ATTACHED

BUYER(S): _____ SELLER(S): _____

Date of Offer: 11/1/07 Date of Acceptance: _____ (This date shall be inserted only after the parties hereto have agreed to all the terms and conditions of this Contract and is also referred to herein as the Contract Date).

IDENTITY OF ATTORNEYS
(Please complete when executing the Contract)

Buyer's Attorney: Law Offices of Ronald N. Primack, L.L.C. Seller's Attorney: Scott R. Wheaton
 Address: 18401 S. Maple Creek Drive, Suite 100, Tinley Park, IL 60477 Address: 18143 Greenwood, Lansing, IL 60438
 Telephone: 708-444-0277 Telephone: 708-895-2200
 Fax: 708-444-4149 Fax: 708-895-4089

case/lamar/Lake Co Trust/ Agreement Rev D3 individual for 3 parcels

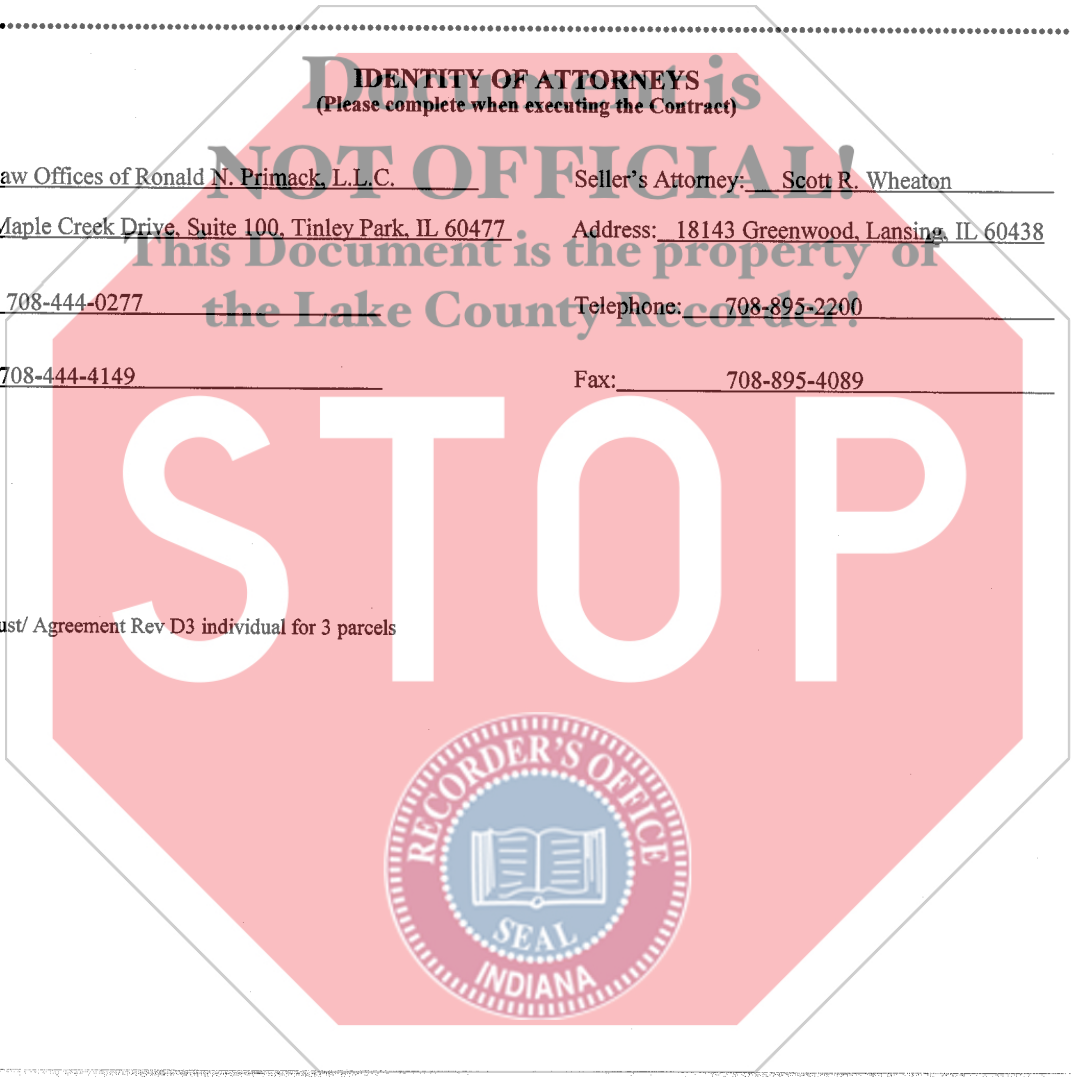

It is expressly understood and agreed by and between the parties hereto, anything herein to the contrary notwithstanding, that each and all of the warranties, indemnities, representations, covenants, undertakings and agreements herein made on the part of the Trustee while in form purporting to be the warranties, indemnities, representations, covenants, undertakings and agreements of said Trustee are nevertheless each and every one of them, made and intended not as personal warranties, indemnities, covenants, undertakings and agreements by the Trustee or for the purpose or with the intention of binding said Trustee personally but are made and intended for the purpose of binding only that portion of the trust property specifically described herein, and this instrument is executed and delivered by said Trustee not in its own right, but solely in the exercise of the powers conferred upon it as such Trustee; and that no personal liability or personal responsibility is assumed by nor shall at any time be asserted or enforceable against LAKE COUNTY TRUST COMPANY on account of this instrument or on account of any warranty, indemnity, representation, covenant, undertaking or agreement of the said Trustee in this instrument contained, either expressed or implied, all such personal liability, if any, being expressly waived and released.

Nothing contained herein shall be construed as creating any liability on LAKE COUNTY TRUST COMPANY, personally under the provisions of the Comprehensive Environmental Response, Compensation and Liability Act (CERCLA) or the Indiana Responsible Property Transfer Law (the Act) as amended from time to time or any other Federal, State or local law, rule or regulation. LAKE COUNTY TRUST COMPANY, personally is not a "Transferor or Transferee" under the Act and makes no representations concerning any possible environmental defects. In making any warranty herein the Trustee is relying solely on information furnished to it by the beneficiaries and not of its own knowledge and specifically exculpates itself from any liabilities, responsibilities or damages as a result of including any warranty in this instrument.

The information contained in this instrument has been furnished the undersigned by the beneficiaries under aforesaid Trust and the statements made therein are made solely in reliance thereon and no responsibility is assumed by the undersigned, in its individual capacity for the truth or accuracy of the facts herein stated.

(Page 1 of 2 pages of Trustee's)



IN WITNESS WHEREOF, LAKE COUNTY TRUST COMPANY, not personally but as Trustee as aforesaid, has caused these presents to be signed by its Trust Officer this 19th day of October, 2007.

LAKE COUNTY TRUST COMPANY, not personally but as Trustee under the provisions of a Trust Agreement dated July 29, 1971, and known as Trust No. 1720.

By: Elaine M. Sievers
Elaine M. Sievers, Trust Officer

STATE OF INDIANA)
) SS:
COUNTY OF LAKE)

Before me, the undersigned, a Notary Public in and for said County and State, personally appeared the within named Officer of LAKE COUNTY TRUST COMPANY, who acknowledged the execution of the foregoing instrument as the free and voluntary act of said Corporation and as her free and voluntary act, acting for such Corporation, as Trustee.

WITNESS my hand and this 19th day of October, 2007.



Hesta Smith
Hesta Smith, Notary Public

My Commission Expires: 10-11-15 Resident of Lake County, Indiana.

(Page 2 of 2 pages of Trustee's Signature Pages)

"I AFFIRM, UNDER THE PENALTIES FOR PERJURY, THAT I HAVE TAKEN REASONABLE CARE TO REDACT EACH SOCIAL SECURITY NUMBER IN THIS DOCUMENT, UNLESS REQUIRED BY LAW."

PREPARED BY: Shawna

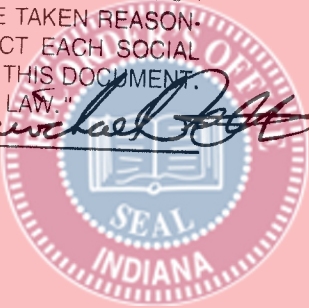

Document is NOT OFFICIAL!
This Document is the property of the Lake County Recorder!

THE **LAMAR** COMPANIES

“Exhibit A”

Lamar Lease _____

Lake County Trust #1720

PROPOSED SIGN EASEMENT NO. 2

A parcel of land in the East half of the Southwest Quarter of Section 9, Township 36 North, Range 7 West of the Second Principal Meridian, in Lake County Indiana, described as follows: Commencing at the Southwest corner of the East half of the Southwest Quarter of said Section 9; thence North 00 degrees 45 minutes 00 seconds West, along the West line of said East Half, 1,386.12 feet to the South right-of-way of the Tri-State Expressway; thence East along said South right-of-way line the next two courses and distances, North 61 degrees 25 minutes 00 seconds East, 21.90 feet; North 62 degrees 44 minutes 00 seconds East, 497.13 feet to the point of beginning of this description: thence continuing along said right-of-way line North 62 degrees 44 minutes 00 seconds East, 71.76 feet; thence South 27 degrees 16 minutes 00 seconds East, 100.00 feet; thence South 62 degrees 44 minutes 00 seconds West, 71.76; thence North 27 degrees 16 minutes 00 seconds West, 100.00 feet to the said right-of-way line and point of beginning. Containing 7,176 square feet, more or less, and subject to all legal highways and easements of record.

Note: This legal description is not the result of a full boundary survey. It is the result of compilation of record information and location of available monumentation.

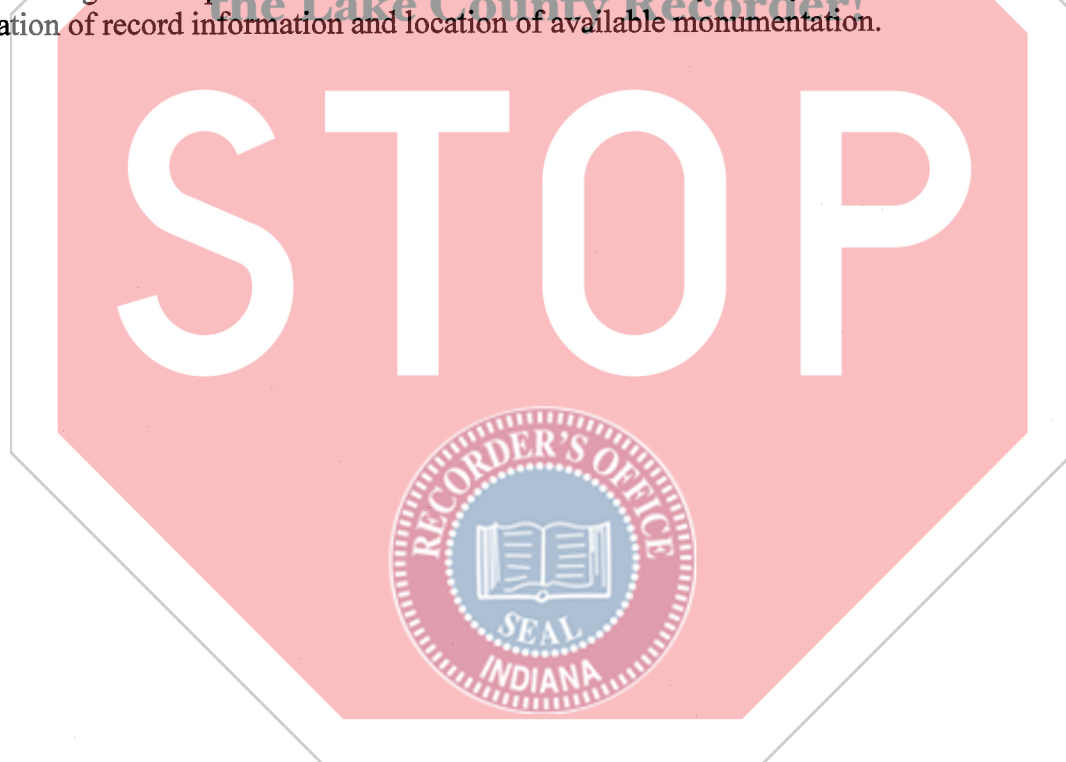

FIRST GROUP ENGINEERING INC.
CONSULTING ENGINEERS

INDIANAPOLIS, INDIANA 46276
TEL (317) 590-0648
FAX (317) 590-0648

POWER POLE	LIGHTPOLE
R/W MARKER	MAG NAIL
IRON PIN FOUND	CONTROL POINT
INLET	HAND HOLE
MANHOLE	SIGN
TRANSFORMER	IRON PIN SET
FIRE HYDRANT	REBAR FOUND
GAS MARKER	TELE. PED.
GAS VALVE	WATER MARKER
GUY ANCHOR	WATER VALVE

SURVEY NOTES
UTILITY INFORMATION IS BASED UPON FIELD MEASUREMENTS AND IS LIMITED ONLY TO THAT WHICH IS VISIBLE AND CAN BE MEASURED. THIS DOES NOT PRECLUDE THE EXISTENCE OF OTHER UNDERGROUND ITEMS. BEFORE CONTACTING ANY CONTRACTOR, CONTACT THE LOCAL MUNICIPALITY AND UTILITY COMPANIES.
THE PERMANENT DUPLICATE NUMBER FOR THE PARENT PROPERTY IS:

SITE DESIGNATION INFORMATION
GL#XX-XXXX-XXXX
SR 51 & 180/94
LAKE STATION, IN 46405

BEARINGS SHOWN HEREON REFER TO WEST LINE OF THE EAST HALF OF THE SOUTHWEST QUARTER OF SEC. 9, T36N, R7W AS N 09°45'00" W
MEAN MAGNETIC DECLINATION OBTAINED FROM U.S.G.S. STATE QUADRANGLE MAP 7 1/2 MINUTE SERIES MAP STATE OF INDIANA

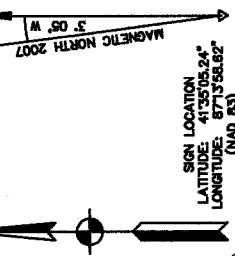

PREPARED FOR
LAMAR
OUTDOOR ADVERTISING
1774 WEST 41ST AVENUE
GARY, INDIANA 46408
TEL (317) 883-3881
FAX (317) 883-1808

DATE	ISSUE/REVISION	BY
10/03/07	90% REVIEW	M.A.N.
PROJECT NO. 07-7388 SHEET 1 OF 1		

EASEMENT DETAILS AND LEGAL DESCRIPTIONS

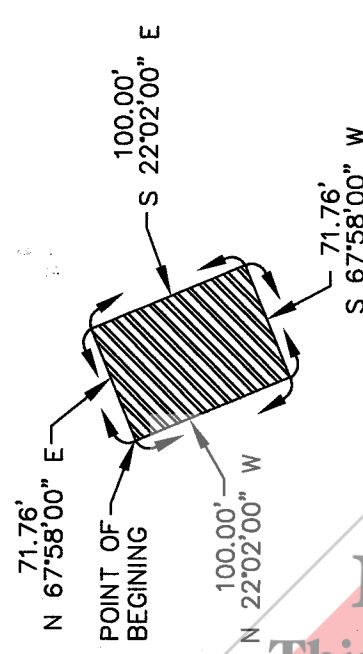

SIGN EASEMENT NO. 3
7,176 Sq. Ft.

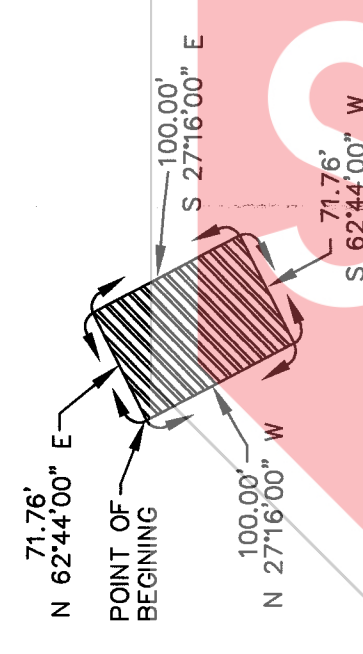

SIGN EASEMENT NO. 2
7,176 Sq. Ft.

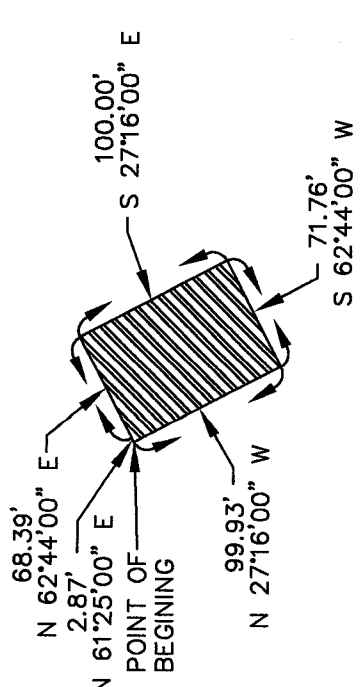

SIGN EASEMENT NO. 1
7,176 Sq. Ft.

PROPOSED SIGN EASEMENT NO. 3

A parcel of land in the East half of the Southwest Quarter of Section 9, Township 36 North, Range 7 West of the Second Principal Meridian, in Lake County, Indiana, is described as follows: Commencing at the Southeast corner of the East half of the Southwest Quarter of said Section 9; thence North 00 degrees 45 minutes 00 seconds West, along the West line of said East half, 1,385.12 feet to the South right-of-way of the Tri-State Expressway; thence East, along said South right-of-way line the next three courses and distances, North 61 degrees 25 minutes 00 seconds East, 21.00 feet, North 82 degrees 44 minutes 00 seconds East, 785.50 feet, North 87 degrees 58 minutes 00 seconds East, 21.80 feet, North 87 degrees 58 minutes 00 seconds East, 71.76 feet; thence South 22 degrees 02 minutes 00 seconds West, 100.00 feet; thence South 02 minutes 00 seconds West, 100.00 feet to the said right-of-way line and point of beginning. Containing 7,176 square feet, more or less, and subject to all legal highways and easements of record.

Note: This legal description is not the result of a full boundary survey. It is the result of compilation of record information and location of available monumentation.

PROPOSED SIGN EASEMENT NO. 2

A parcel of land in the East half of the Southwest Quarter of Section 9, Township 36 North, Range 7 West of the Second Principal Meridian, in Lake County, Indiana, is described as follows: Commencing at the Southeast corner of the East half of the Southwest Quarter of said Section 9; thence North 00 degrees 45 minutes 00 seconds West, along the West line of said East half, 1,385.12 feet to the South right-of-way of the Tri-State Expressway; thence East, along said South right-of-way line the next three courses and distances, North 61 degrees 25 minutes 00 seconds East, 21.80 feet, North 87 degrees 58 minutes 00 seconds East, 487.13 feet to the point of beginning of this description; thence containing along said right-of-way line North 02 degrees 44 minutes 00 seconds East, 71.76 feet; thence South 27 degrees 16 minutes 00 seconds West, 71.76 feet; thence North 27 degrees 02 minutes 00 seconds West, 100.00 feet to the said right-of-way line and point of beginning. Containing 7,176 square feet, more or less, and subject to all legal highways and easements of record.

Note: This legal description is not the result of a full boundary survey. It is the result of compilation of record information and location of available monumentation.

PROPOSED SIGN EASEMENT NO. 1

A parcel of land in the East half of the Southwest Quarter of Section 9, Township 36 North, Range 7 West of the Second Principal Meridian, in Lake County, Indiana, is described as follows: Commencing at the Southwest corner of the East half of the Southwest Quarter of said Section 9; thence North 00 degrees 45 minutes 00 seconds West, along the West line of said East half, 1,385.12 feet to the South right-of-way of the Tri-State Expressway; thence East, along said South right-of-way line, North 61 degrees 25 minutes 00 seconds East, 45.03 feet, North 87 degrees 58 minutes 00 seconds East, 2.87 feet, North 82 degrees 44 minutes 00 seconds East, 68.39 feet; thence South 27 degrees 16 minutes 00 seconds East, 100.00 feet; thence South 02 degrees 44 minutes 00 seconds West, 71.76 feet; thence North 27 degrees 16 minutes 00 seconds West, 99.83 feet to the said right-of-way line and point of beginning. Containing 7,176 square feet, more or less, and subject to all legal highways and easements of record.

Note: This legal description is not the result of a full boundary survey. It is the result of compilation of record information and location of available monumentation.

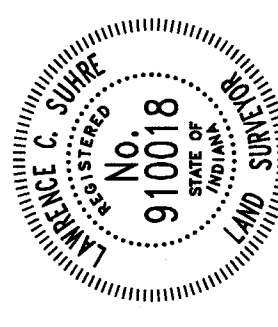
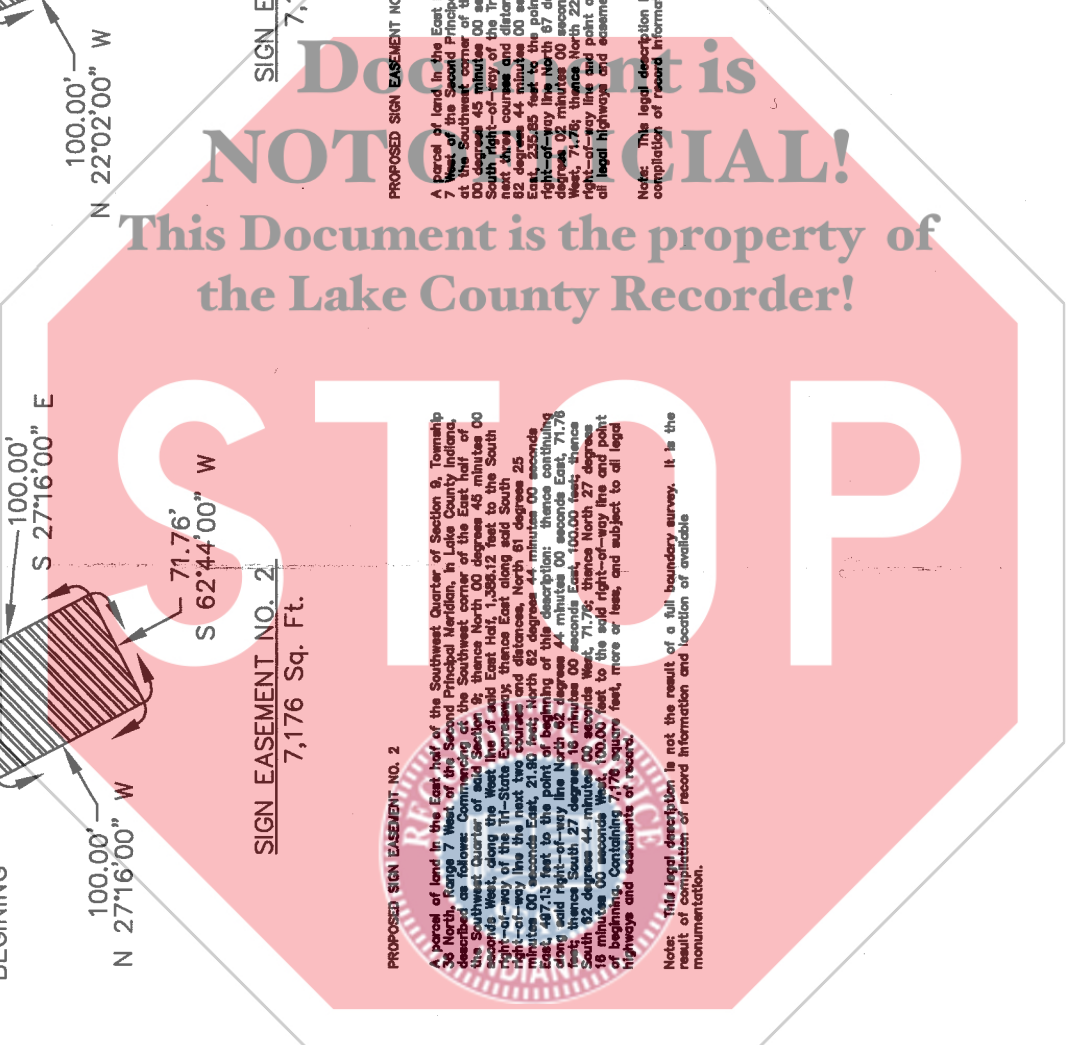

10/03/07
Lawrence C. Suhre

Document is NOT OFFICIAL!
This Document is the property of the Lake County Recorder!

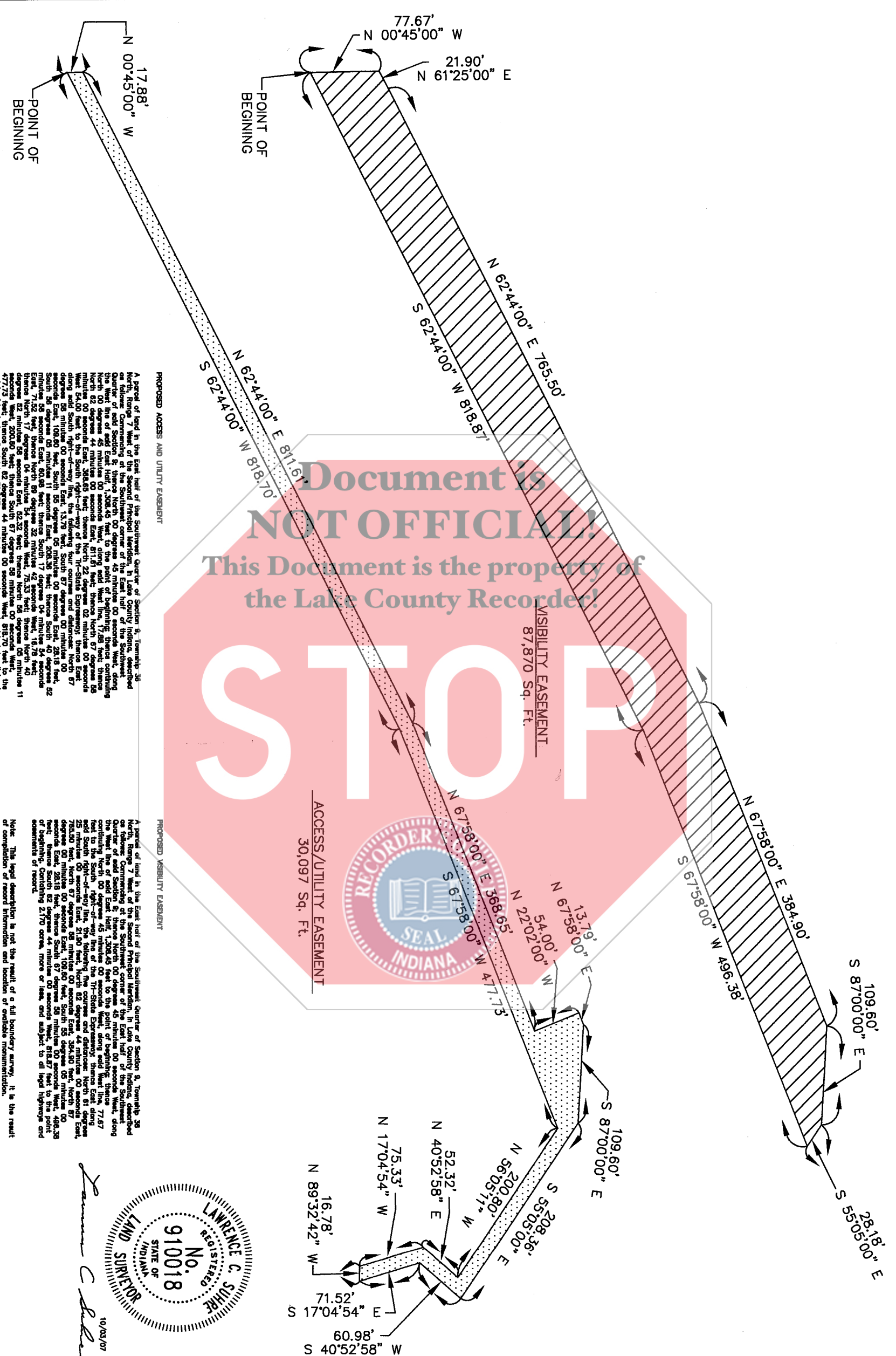
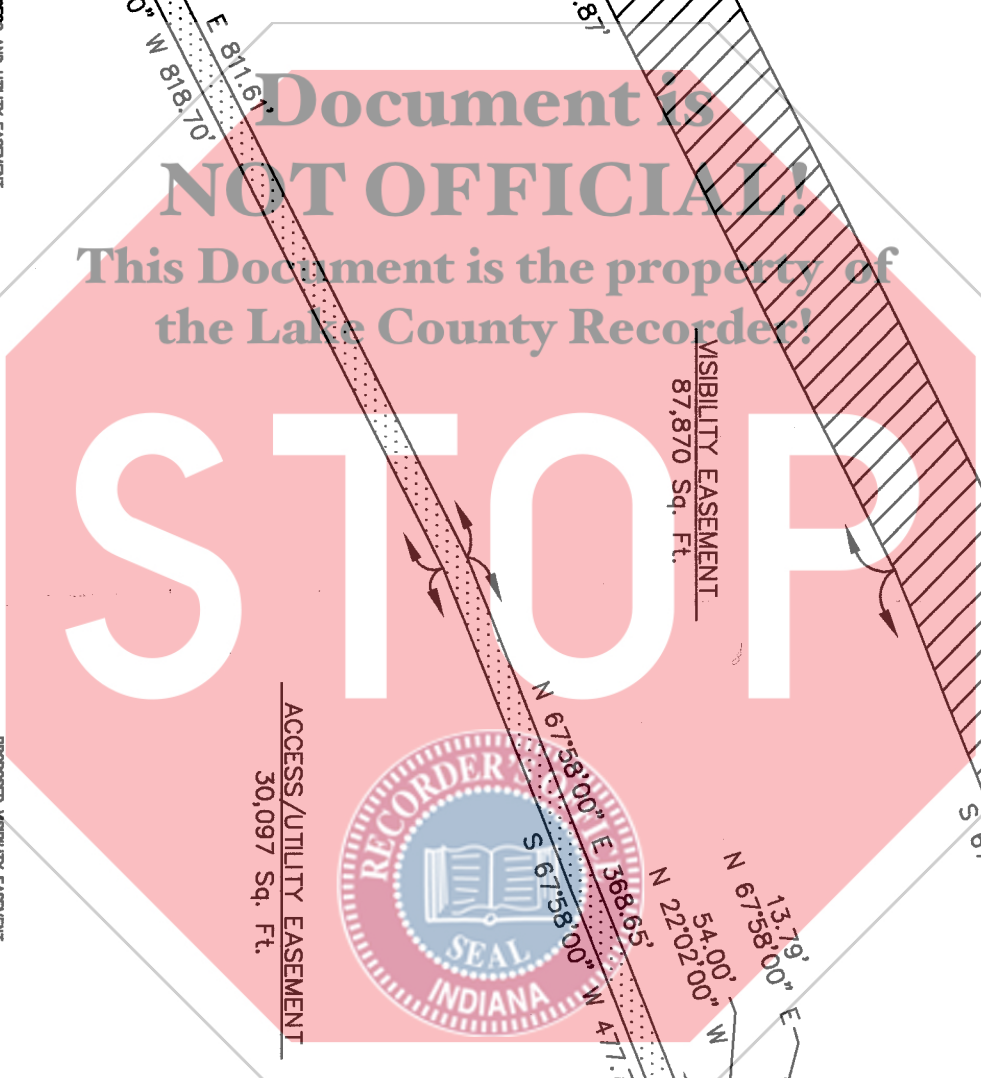

PROPOSED ACCESS AND UTILITY EASEMENT

A parcel of land in the East half of the Southwest Quarter of Section 9, Township 36 North, Range 7 West, of the Second Principal Meridian, in Lake County, Indiana, described as follows: Commencing at the southwest corner of the East half of the Southwest Quarter of said Section 9, thence South 89 degrees 32 minutes 42 seconds West, along the line of said East Half, 1,208.45 feet to the point of beginning, thence North 00 degrees 45 minutes 00 seconds West, along said West line, 17.88 feet, thence North 00 degrees 45 minutes 00 seconds West, along said West line, 17.88 feet, thence North 82 degrees 45 minutes 00 seconds East, 611.61 feet, thence North 67 degrees 58 minutes 00 seconds East, 384.90 feet, thence North 22 degrees 02 minutes 00 seconds West, 811.61 feet, thence North 00 seconds West, 818.70 feet to the point of beginning, containing 87,870 square feet, more or less, and subject to all legal easements of record.

PROPOSED VISIBILITY EASEMENT

A parcel of land in the East half of the Southwest Quarter of Section 9, Township 36 North, Range 7 West, of the Second Principal Meridian, in Lake County, Indiana, described as follows: Commencing at the southwest corner of the East half of the Southwest Quarter of said Section 9, thence South 89 degrees 32 minutes 42 seconds West, along the line of said East Half, 1,208.45 feet to the point of beginning, thence North 00 degrees 45 minutes 00 seconds West, along said West line, 17.88 feet, thence North 00 degrees 45 minutes 00 seconds West, along said West line, 17.88 feet, thence North 82 degrees 45 minutes 00 seconds East, 611.61 feet, thence North 67 degrees 58 minutes 00 seconds East, 384.90 feet, thence North 22 degrees 02 minutes 00 seconds West, 811.61 feet, thence North 00 seconds West, 818.70 feet to the point of beginning, containing 87,870 square feet, more or less, and subject to all legal easements of record.

ACCESS/UTILITY EASEMENT
30,097 Sq. Ft.

ACCESS/UTILITY EASEMENT
30,097 Sq. Ft.

FIRST GROUP ENGINEERING INC.
CONSULTING ENGINEERS
INDIANAPOLIS, INDIANA 46278
TEL (317) 290-8848
FAX (317) 290-8860

UTILITY NOTES	
POWER POLE	LIGHTPOLE
R/W MARKER	MAG NAIL
IRON PIN FOUND	CONTROL POINT
INLET	HAND HOLE
MANHOLE	IRON
TRANSFORMER	IRON PIN SET
FIRE HYDRANT	REBAR FOUND
GAS MANGER	TELE. PED.
GAS VALVE	WATER MARKER
GUY ANCHOR	WATER VALVE

UTILITY INFORMATION IS BASED UPON FIELD MEASUREMENTS AND IS SUBJECT TO THAT WHICH IS VISIBLE AND CAN BE MEASURED. THIS DOES NOT PRECLUDE THE EXISTENCE OF OTHER UNDERGROUND ITEMS. BEFORE BEGINNING CONSTRUCTION, CONTACT RECORDING MUNICIPALITY AND UTILITY COMPANIES.
THE PERMANENT DUPLICATE NUMBER FOR THE PARENT PROPERTY IS:

SITE DESIGNATION INFORMATION
GL#XX-XXXX-XXXX
SR 51 & 180/94
LAKE STATION, IN 46405

BEARINGS SHOWN HEREON REFER TO WEST LINE OF OR THE EAST HALF OF THE SOUTHWEST QUARTER OF SEC. 9, T36N, R7W, AS N 00°45'00" W
MEAN MAGNETIC DECLINATION
7 1/2 MINUTE SERIES U.S.G.S. GARY QUADRANGLE
STATE OF INDIANA

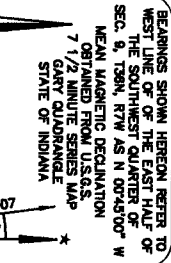

LAND SURVEYOR
LAWRENCE C. SUHRE
REGISTERED
NO. 910018
STATE OF INDIANA
10/03/07

LAWRENCE C. SUHRE
PREPARED FOR
OUTDOOR ADVERTISING
1771 WEST 41ST AVENUE
GARY, INDIANA 46408
TEL (317) 890-1808
FAX (317) 890-1808

DATE	ISSUE/REVISION	BY
10/03/07	908 REVIEW	M.A.N.

PROJECT NO. 07-7389 SHEET 1 OF 1

EASEMENT DETAILS AND LEGAL DESCRIPTIONS