

5265 ...
...

700

KNOW ALL MEN, That

3 737554

Michael L. Horvath and Maria J. Horvath, husband and wife

herein called the "grantors", in consideration of the sum of one dollar (\$1.00) and other valuable considerations, in hand paid to the grantors, hereby grant to NORTHERN INDIANA PUBLIC SERVICE COMPANY, an Indiana corporation, and to its successors and assigns, the right and authority to construct, erect, maintain, operate, repair, replace and renew anchors and guys, in, upon, and over a strip of land situated in Section.....13....., Township.....35N....., Range.....10W..... of the Second Principal Meridian in the county of.....Lake....., State of Indiana, and described as follows:

14-23-18

A parcel of land ten foot (10') by twenty foot (20') located at the southeast corner of Lot 18 of Block 18 of Hart's Addition to Dyer.

See Exhibit "A" attached hereto and made a part hereof, for legal description.

FILED

DEC 9 1983

Lucie O. Priddy
AUDITOR LAKE COUNTY

STATE OF INDIANA
CLERK OF SUPERIOR COURT
FILED FOR RECORD
DEC 14 10 55 AM '83
WILLIAM J. SELSKI JR
RECORDER

The grantors reserve the use of said strip of land not inconsistent herewith, but no buildings or structures shall be erected or placed on said strip of land by grantors.

The grantee shall and will indemnify and save the grantors harmless from and against any and all damage, injuries, losses, claims, demands or costs proximately caused by the fault, culpability, or negligence of the grantee in the construction, erection, maintenance, operation, repair or removal of said anchors and guys in, upon and over said strip of land.

Access to the above described land over the adjoining lands of the grantor is hereby granted. Any damage to the crops, tile, fences, or buildings of the grantors on said strip of land, or on lands of the grantors adjoining said strip of land done by the grantee in the construction, erection, maintenance, operation, repair, replacement or renewal of said anchors and guys, shall be promptly paid for by the grantee.

The grantee may cut or trim trees, bushes and saplings growing upon or extending over said strip of land so far as may be reasonably necessary in the construction, operation and maintenance of said anchors and guys.

These presents to be binding on the heirs, executors, administrators, grantees and assigns of the grantors, and upon the grantee, its successors and assigns.

IN WITNESS WHEREOF, the grantors have duly executed this instrument this.....5th.....day of December....., A. D. 19 83.....

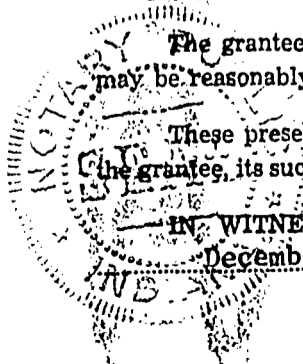

Michael L. Horvath (SEAL)
Michael L. Horvath
Maria J. Horvath (SEAL)
Maria J. Horvath

700

35355

EXHIBIT "A"

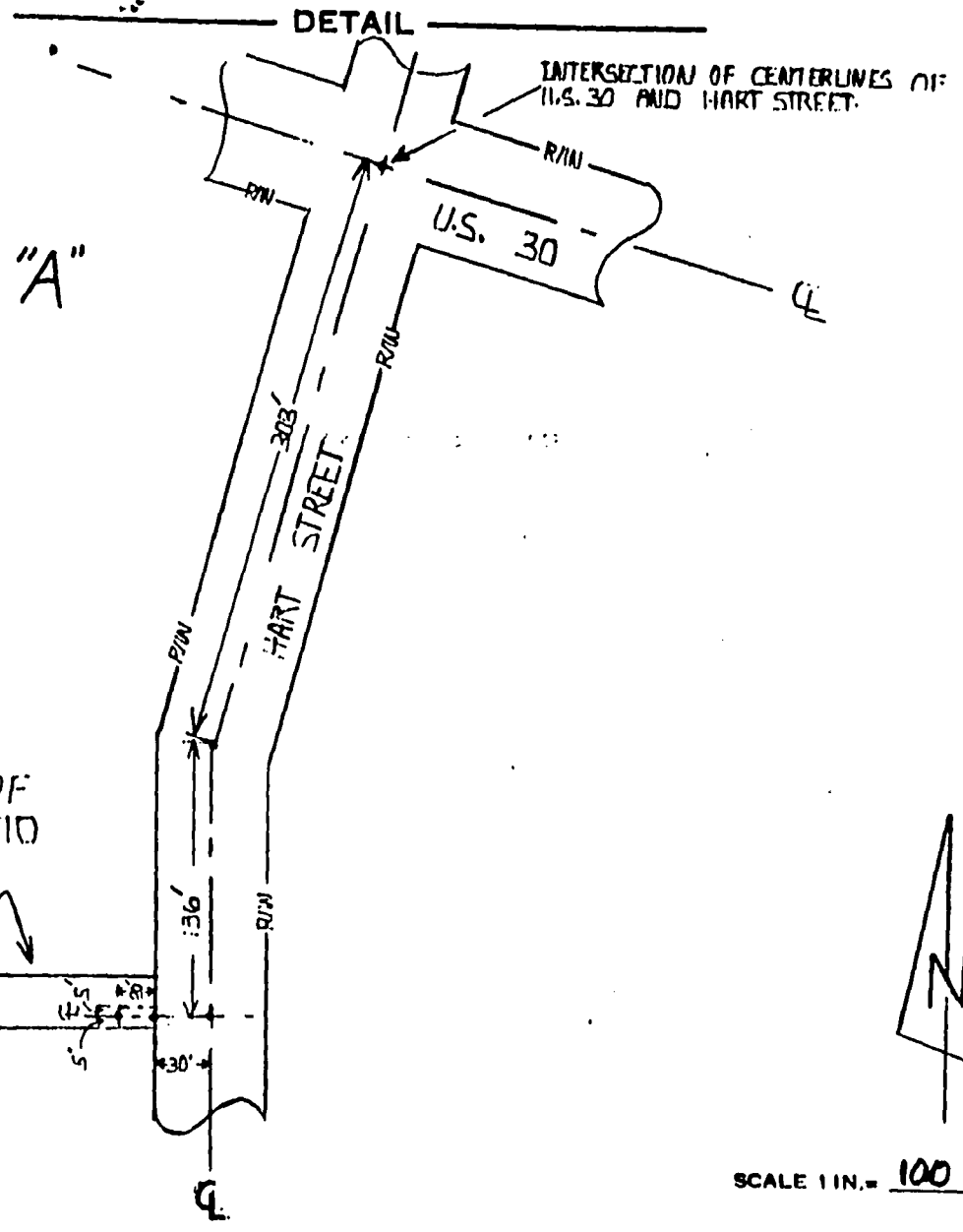

14-15

BLOCK 18, LOT 19 OF HART'S ADDITION TO DYER



SCALE 1 IN. = 100 FT.

TOP VIEW

